

Dynavec DV507 Tone arm Instruction Manual

INDEX

Here appears the new bi-axis tone arm Dynavec DV507 designed on the same theoretical base of DV505 and DV501 which are recognized and appreciate highly by their outstanding performance and thus given the Design and Engineering Award at C.E.S. Chicago 1977 and 1982. DV507 has more theoretical improvement as well as the more conventional in the actual use.



1. [Foreword](#)
2. [Parts illustration](#)
3. [Installation to turntable](#)
4. [Output line connection](#)
5. [Cartridge installation and adjustments](#)
6. [Specifications](#)

1. Foreword

Thank you for choosing Dynavec products. DV507 is a specially designed tone arm which can reproduce the signal on disc without influence caused by disc warp. In order to perform its unique specifications including bi-axis inertia separation to vertical and lateral directions, the DV507 has a more complicated structure compared to conventional tone arms.

However, it is quick and easy to set up, provided that you should read this instruction manual carefully first.

2. Parts illustration

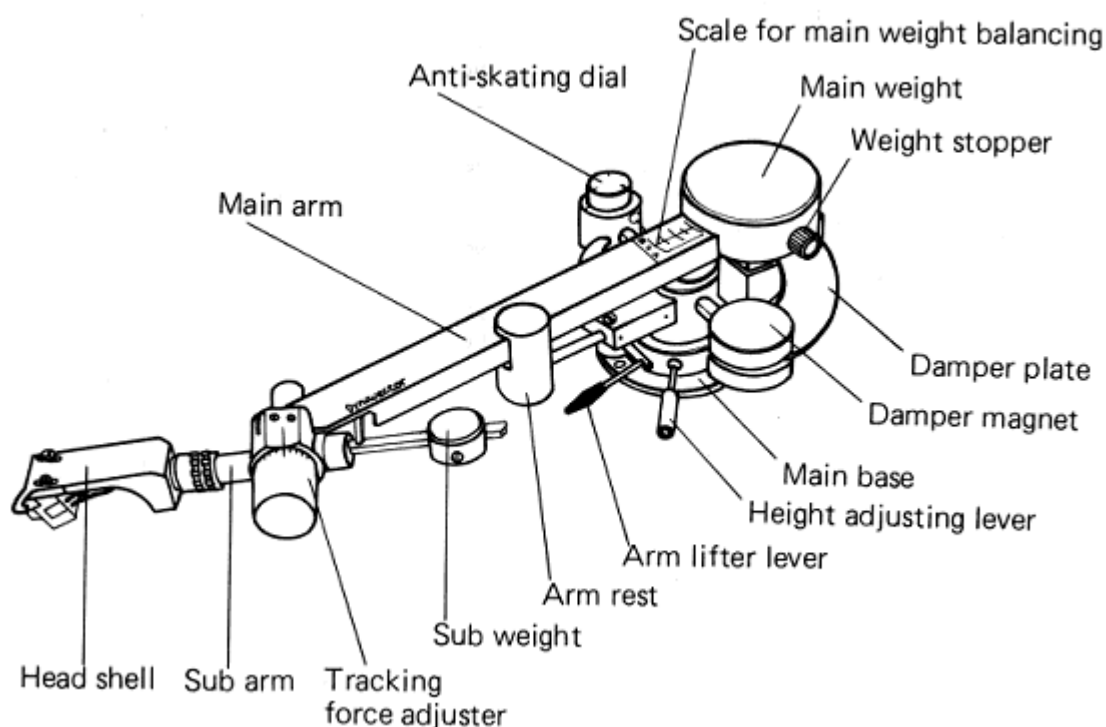

Fig.1

3. Installation to turntable

For mounting the DV507 you will first require an accurately placed hole in the deck. This can easily be obtained using the enclosed paper template.

After marking the holes' center drill out to a diameter of 29 or 30mm. Test the arm in the mounting hole. Mark the position of the DV507's small fixing holes on ARM BASE, remove the arm and then make three small holes at these positions using a gimlet or sharp instrument. The arm can now be secured to the board using the screws provided.

CAUTION

- There are no rubbers or felt washers provided as these detract from the performance in today's modern turntables.
- Please keep the DV507 in its box whilst drilling holes to avoid any damage to the arm. .

4. Output line connector

Insert the DV507's cable to the output terminal which is situated under the DV507.

There will be a 2-5mm allowance between the plug and outer pipe of the DV507 to enable you to use other types of lead should you wish to do so. (See Fig. 2)

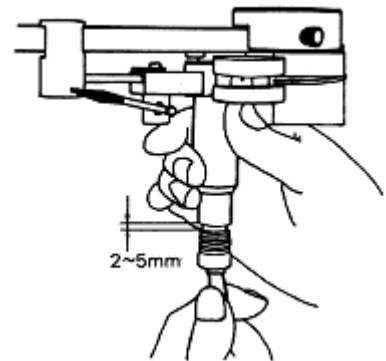

Fig.2

5. Cartridge installation and adjustments

Please follow these six points when installing your cartridge in the DV507.

1. **Damper plate check**
2. **Overhang adjustment for the cartridge in headshell.**
3. **Main weight balance position**
4. **Tracking force setting.**
5. **Tone arm height adjusting**
6. **Bias adjustment.**

These checks can be carried out as follows

1. Damper plate check

Gently rotate the Main Arm. If the Damper Plate moves freely through the Damper Magnet slit no further action is necessary. If, however, the plates' movement is restricted by touching or rubbing on the magnet you will need to gently bend the plate with your finger to avoid obstruction.

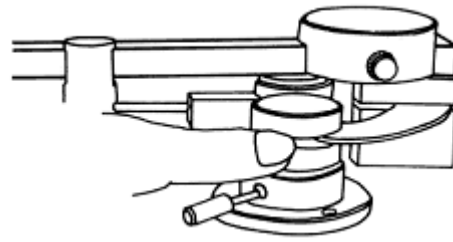

Fig.3

Please be careful not to over bend this delicate part of the arm, any adjustment should be minor and free running of the damper plate soon obtained. Avoid knocking or touching the plate after it has been set. Be careful not to scratch the painted surface. (see Fig. 3).

2. Cartridge mounting and overhang adjustment

Correct adjustment for the overhang is needed to obtain good performance of cartridge.

Fix the cartridge to the headshell after adjustment for the overhang as cartridge stylus tip is exactly over the mark on the the aluminum template we supplied.

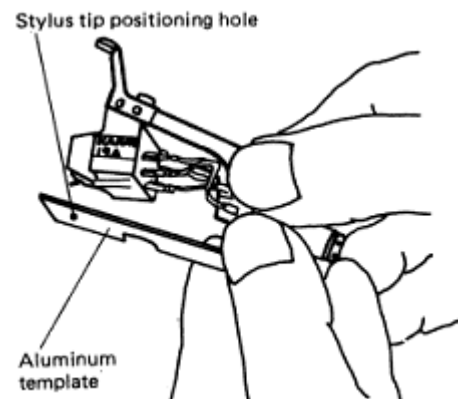

Fig4.

3. Main weight balance

As you are aware the DV507 is in fact two arms in one. In the horizontal plane it has very heavy inertia careful balancing with the main weight is therefore required in order for the main arm to rotate smoothly.

DV507 has three kinds of sub weight balancer A, B and C due to the total weight of headshell plus cartridge itself. The actual DV headshell weight of 15 grams should be added to the cartridge weight for selecting one from these three sub weights. In this case please refer to the next table.

In the end of the main arm there are three scale indications due to the sub weight. For instance when the total weight is 20 grams, choose the sub weight A, and adjust the top end of main weight to the line of 20 of scale A (see Fig. 5) .

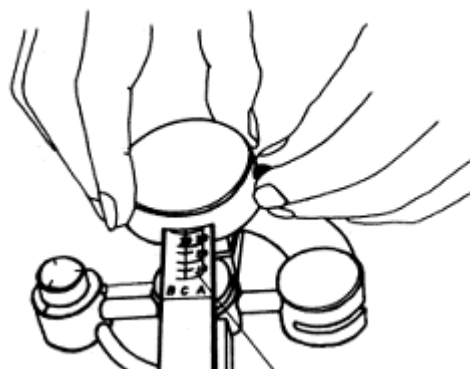



<Table: How to choose the sub weight>

Total weight	Sub weight
15~23 grs	A
20~33 grs	C
25~35 grs	B

4. Tracking force setting

Insert the sub weight onto the sub arm with the weight screw facing towards you (it will not fit if the screw faces the main arm Fig. 6)

First set tracking force adjuster to zero point and balance sub arm precisely level by sliding sub weight to right position, Sub arm so balanced, turn adjuster finger screw to obtain necessary tracking force. Adjuster scale is graduated by 0.2grams and between graduation marks, too, adjustment is done progressively in proportion to adjuster screw advance.

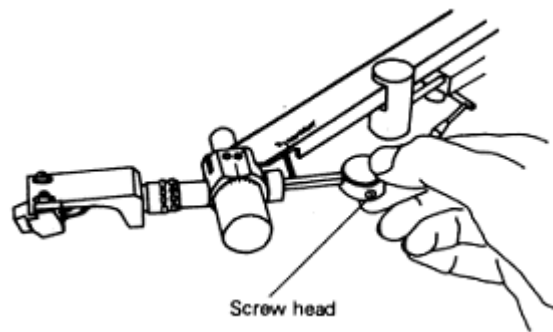

Fig.6

CAUTION

In DV507, you can notice the sub weight bar is flexible at the bottom. This is not by the defect of the bearing but for the damping, effect for the smoother performance at mid frequency range.

5. Tone arm height adjusting

Firstly, loosen the fixing screw by which you can adjust the height of the tone arm roughly. Afterward fix this screw rigidly. Then loosen the height adjusting lever by twisting anticlockwise, thereafter by moving this lever to and fro, you can adjust the height more precisely.

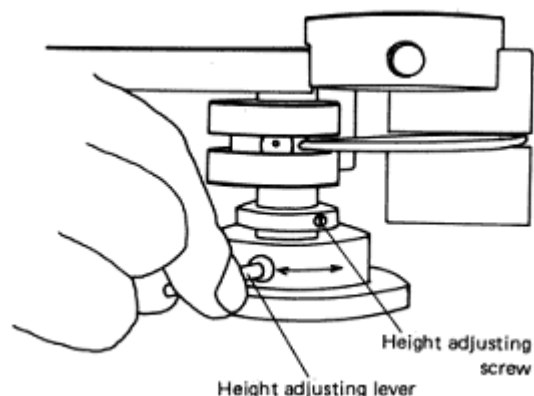

Fig.7

Then lock this lever to the optimum position by twisting clockwise. 7mm is adjustable by this lever. (see Fig. 7)

6. Bias adjustment

For adjusting the antiskating force, make sure that the dial indication of the antiskate dial should coincide with the playing weight value.

But in some case due to the recording condition or stylus shape, you are required and allowed to readjust to the other dial indication to obtain the better result.

All adjustments and setting up are now completed, Your DV507 arm is designed to be maintenance free. It will give long and reliable service but should be treated with care and kept in a dust free condition.

Should the arm require an overhaul or if you need any other quations or spare parts for your DV507 please contact your dealer or Dynavector distributor.

6. Specifications

System	Bi-axis inertia controlled dynamic and eddy current damping dynamic balance type tone arm
Total length	306mm (including headshell)
Effective length	241mm
Overhang	15mm
Offset angle	21.5 degree
Height	59mm (liftable up to 92mm)
Depth	36mm (without connecting cable)
Height adjustability	39-72mm (at sub arm center)
Optimum cartridge weight	15 - 35grms (including headshell)
Tracking force adjustability	0 - 3grams by 0.2grams step
Lateral tracking angle error	-1.1 degree to +2.2 degree (0 degree at inner band of record disk, 2.2 degree at outside)
Motion sensitivity	Lateral -- less than 50 mgrams Vertical -- less than 40 mgrams
Net weight	1,380 grams
Output connector	5P connector with low resistance cord 0.025 ohms/m, 50pF/m
Head connector:	EIA standards
Head shell	Aluminum diced and milled (weight 15grams)

(December/3/2001)